

INSTRUCTION MANUAL

FUNCTION GENERATOR

MODEL 4500

KIKUSUI ELECTRONICS CORPORATION

8/1/6

812222

TABLE OF CONTENTS

	<u>PAGE</u>
1. GENERAL	1
2. SPECIFICATIONS	2
3. OPERATING INSTRUCTIONS	4
3.1 Explanation of Front Panel	4
3.2 Explanation of Rear Panel	5
3.3 Notes for Use	7
4. OPERATING PRINCIPLE	9
4.1 Basic Operating Principle	9
4.2 VCG (voltage-controlled generator)	11
4.3 Start/Stop Operation	13
4.4 DC Offset Operation	14
5. APPLICATIONS	15
5.1 Application of VCG	15
5.2 Use of DC Offset	16
5.3 Use as a Clock Generator	16

8122223

1. GENERAL

Model 4500 Function Generator is a high performance instrument which provides an output signal of 0 - 20 Vp-p, 0.001 Hz - 10 MHz sine wave, triangular wave or square wave.

The oscillating frequency can be set with dials in ten decimal ranges or can be controlled with an external voltage in a VCC system for 1000-times change in one range with an external control voltage of 10 mV - 10 V. Oscillation start/stop is controllable with a switch on the front panel.

The output voltage is controllable with a stepwise knob for the 0, -20, -30, -40, -50 and -60 ranges and a continuously variable knob which covers between ranges. A DC offset switch is incorporated to provide a signal superimposed on a DC component.

The function generator also provides a TTL level signal which can be used as a clock signal for digital circuits.

012224

2. SPECIFICATIONS

Name: Function Generator

Model No.: Model 4500

Frequency: 0.001 Hz - 10 MHz



Ranges: $\times 0.001$, $\times 0.01$, $\times 0.1$, $\times 1$, $\times 10$, $\times 100$, $\times 1k$,
 $\times 10k$, $\times 100k$, $\times 1M$

Dial scale: Linear scale, 0.1 - 1 - 100

Accuracy: (at dial scale 1 - 10)

$\times 0.001$ - $\times 100k$ ranges $\pm(2\% + 0.05$ of dial scale)
 $\times 1M$ range $\pm(5\% + 0.05$ of dial scale)

Frequency stability: $\pm 0.5\%$ or less (for $\pm 10\%$ change of line voltage)

Output waveform: Sine wave () , triangular wave ()
or square wave ()

Maximum open output voltage: 20 Vp-p or over

Output resistance: 50Ω

Output voltage control: Attenuator for 0, -20, -40, -50, -60 dB;
continuously-variable adjustment

Frequency response:

0.001 Hz - less than 1 MHz, with reference to 1 kHz ... 0.5 dB or less
1 MHz - 10 MHz, with reference to 1 kHz 3 dB or less

Mutual voltage deviation: $\pm 5\%$ or less (at 1 kHz)

Distortion (Sine wave):

20 Hz - less than 100 kHz 0.6% or less
100 kHz - 600 kHz 1.5% or less

512225

DC offset: Adjustable to \pm (peak value) of maximum output;
effected by pulling the OFFSET knob.

VCG

Control voltage: Approx. 10 mV - 10 V

Controllable frequency: 0.001 Hz - 10 MHz

Ranges: $\times 0.1$ - $\times 1$ M ranges

Variable range: 1000 times or over, within one range

Input resistance: Approx. 10 k Ω or over, single ended

Input frequency range: DC - 1 kHz

Sync output

Level: TTL

Output resistance: 50 Ω

Start/stop: Controllable with front panel switch

Ambient temperature: 5°C - 35°C (41°F - 95°F)

Power requirements: 100 V \pm 10%, 50/60 Hz AC, approx. 30 VA

Dimensions: 200 (W) \times 320 (D) \times 140 (H) mm
(7.88 (W) \times 12.60 (D) \times 5.51 (H) in.)

Maximum dimensions: 200 (W) \times 360 (D) \times 160 (H) mm
(7.88 (W) \times 14.18 (D) \times 6.30 (H) in.)

Weight: Approx. 5 kg (11 lbs)

Accessory: Instruction manual 1 copy

229

3. OPERATING INSTRUCTIONS

3.1 Explanation of Front Panel (See Figure 1.)

- ① POWER: When this pushbutton switch is depressed and locked, the instrument power is turned on and the power pilot lamp (LED) lights.
- ② RANGE: Selects the oscillating frequency range. The dial reading multiplied by the selected range value is the oscillating frequency.
When in DIAL mode: 0.001 - 1 M (all ranges)
When in VCG mode: 0.1 - 1 M (green letters)
- ③ FREQUENCY: Continuously variable adjustment of the oscillating frequency. The frequency increases as this dial is turned clockwise.
- ④ FREQUENCY VARIABLE: For fine adjustment of frequency. When set in the CAL'D position, the oscillating frequency is the dial value multiplied by the range value.
- ⑤ VCG: Selects between VCG mode and DIAL mode. The depressed and locked state is for VCG.
- ⑥ START: Start/stop control of frequency oscillation. When depressed and locked, the oscillation starts and continues.

01122221

- ⑦ DC OFFSET: For superposing a DC component on the oscillated AC component. The DC component is provided when this switch is pulled out and it is continuously variable adjustable up to the maximum peak value of the output voltage. If the sum of DC component and AC component exceeds ± 10 V, the signal is saturated. Operate within ± 10 V.
- ⑧ FUNCTION: Selects the output signal waveform for sine (\sim), triangular (∇), or square (\square).
- ⑨ ATTEN: Attenuator for stepwise attenuation (0, -20, -40, -50, -60 dB) of output voltage. The inner knob is for continuously variable adjustment between ranges.
- ⑩ OUTPUT TERMINAL: Provides the output signal of 0 - 20 V_{p-p}, with output resistance 50 Ω . BNC terminal with the ground line isolated from the casing.
- ⑪ TTL OUTPUT: Provides TTL level output signal synchronized with the oscillating frequency. The output resistance is 50 ohms.
- ⑫ VCG INPUT TERMINAL: Input terminal for VCG mode, to control the oscillating frequency with an input voltage of 10 mV - 10 V.

3.2 Explanation of Rear Panel (See Figure 3-2.)

- ⑬ FUSE: Fuse in the AC power line. 0.5 A
- ⑭ POWER CORD: To be connected to an AC power line outlet of 100 V, 50/60 Hz.

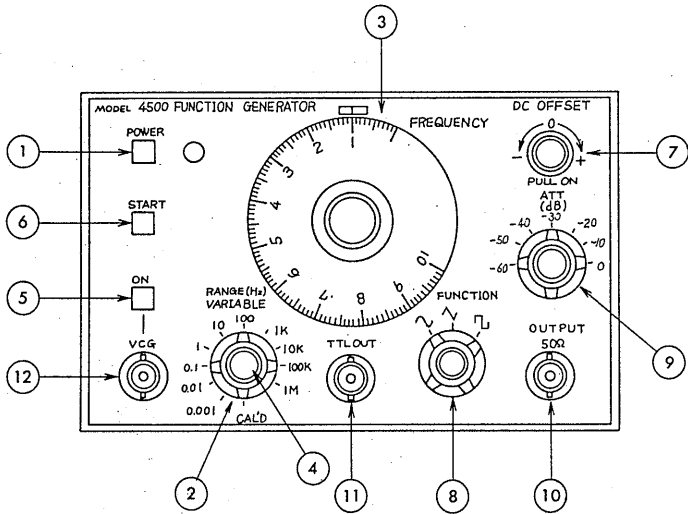

Figure 3-1

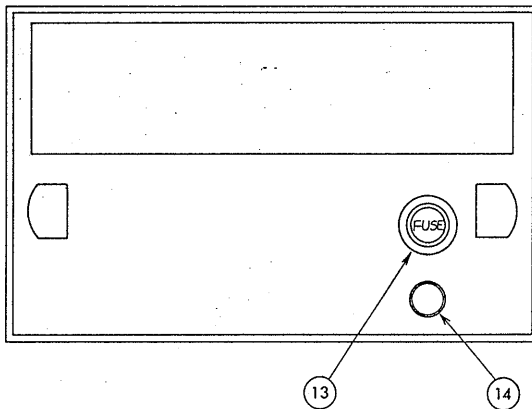

Figure 3-2

3.3 Notes for Use

3.3.1 Precaution for Operation

- (1) The instrument is shipped from the factory upon full electrical and mechanical inspection. When the instrument is delivered to you, immediately unpack it and check for damage which might have been caused when in transportation. If any damage or malfunctioning is found, immediately notify the dealer through whom you purchased this instrument.
- (2) The power requirements are 100 V \pm 10%, 50/60 Hz AC. Note that the instrument may not operate properly or may be damaged if an abnormal voltage is applied.
- (3) The performance specifications of this instrument are guaranteed when used in an ambient temperature range of 5°C to 35°C (41°F to 95°F). If it is used in an ambient temperature not within this range, the performance specifications may not be met and, moreover, the instrument may be damaged.
- (4) The signal ground line is isolated from the casing.
- (5) The dial plate rotates very lightly. Do not rotate it with an unreasonably large force lest its stopper should be broken.

3.3.2 Notes for When In Use

- (1) When using the instrument with a low the output voltage, a better waveform can theoretically be obtained by attenuating the signal with the attenuator and finely adjusting with the continuously-variable knob.
- (2) Avoid shorting the OUTPUT terminal or TTL OUT terminal so far as avoidable.

- (3) The output resistance of this instrument is 50 ohms.
Note that the effect of load capacitance will become
conspicuous at higher ranges.

4. OPERATING PRINCIPLE

4.1 Basic Operating Principle

A basic block diagram of the Function Generator is shown in Figure 4-1. The instrument is composed of flip-flops, integrator, voltage comparator, and sine wave synthesizer.

Assume that, at the instant the power is turned on, the charge of the integrating capacitor (C) is zero and the potential of point "a" of the flip-flop is +E (V) as initial states. The potential of output point "b" of the integrator, consisting of an integrating capacitor and buffer amplifier with gain 1, rises with a positive gradient. When the potential has risen to the reference value +E_r (V), the voltage comparator operates, a trigger signal is generated, the flip-flop is inverted, and the potential of point "a" become -E (V). Consequently, the potential of integrator output point "b" starts falling. When the potential has reached the reference value -E_r (V), the voltage comparator operates, a trigger signal is generated, and the flip-flop returns to the initial states. The above actions are repeated to maintain oscillation.

The frequency is determined by the voltage of point "a", integrating resistance, integrating capacitance, and the reference voltage of the voltage comparator. In general, integrating resistance R₂ and capacitance C are used to determine the range and the voltage of point "a" is varies with R₁ for continuously-variable frequency adjustment.

The reference voltage E_r (V) of the voltage comparator is fixed.

A sine wave is obtained by applying to synthesizer the triangular wave generated by the oscillator circuit.

3100032

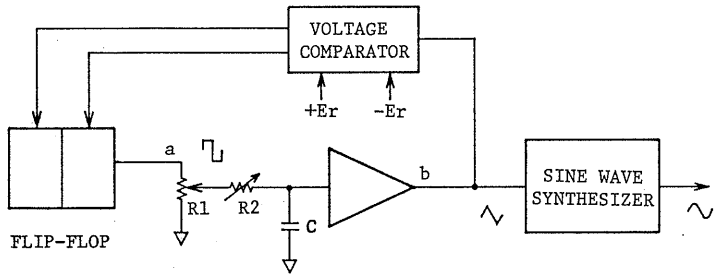

Figure 4-1

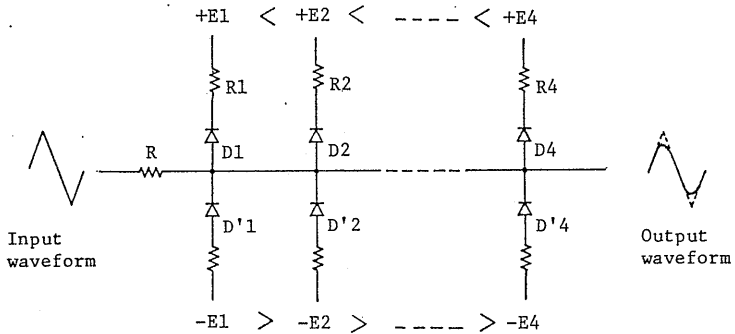

Figure 4-2

The operating principle of the synthesizer is shown in Figure 4-2. Diodes D1 - D4 and D'1 - D'4 are connected with series resistors which are weighted so that the approximation values of the broken-lines become optimal.

When instantaneous value "e" of the triangular input is $0 < e < +E_1$, all diodes are OFF. The gradient of the input waveform is unaltered and the input signal is directly fed to the output circuit.

When the input signal has become $+E_1 < e < +E_2$, diode D1 is turned ON and the gradient of the output is reduced to $R_1/(R_1 + R_2)$. Further, as diodes D2 D4 are sequentially turned ON, the gradient becomes still more gentle.

For a negative voltage also, diode D'1 - D'4 are sequentially turned ON for gradient conversion.

Thus, the triangular wave is converted into a sinusoidal wave in a broken-line approximation method.

4.2 VCG (voltage-controlled generator)

A generator or oscillator the oscillating frequency of which is controlled with a voltage is called VCG or VCO. The oscillating frequency of a VCG is controlled by producing a +/- integration voltage which is proportional to the input voltage or by producing a +/- integration current. For this instrument, the latter current method is employed from the viewpoint of attaining a wider variable range.

A block diagram of the VCG circuit of this instrument is shown in Figure 4-3.

817734

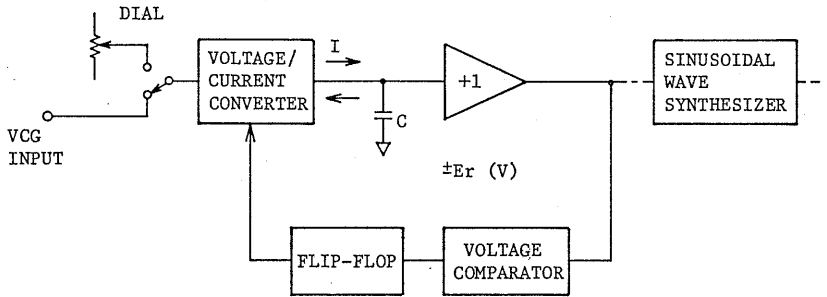

Figure 4-3

Denoting by I the constant current with which the integrating capacitor C is charged and discharged, by $\pm E_r$ the reference voltage of the voltage comparator, and by t the period from $+E_r$ to $-E_r$ as shown in Figure 4-4, equation (1) can be written.

$$\frac{1}{C} \int Idt = 2E_r$$

$$\frac{I}{C} t = 2E_r$$

$$t = 2ErC/I \dots\dots (1)$$

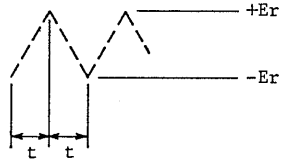

Figure 4-4

The oscillating frequency can be written as follows referring to Figure 4-4.

$$f = 1/2t \dots\dots\dots (2)$$

From equations (1) and (2), the following equation yields:

$$f = I/4 Er C \dots\dots\dots (3)$$

As capacitance C and reference voltage E_r of equation (3) are maintained constant, the oscillating frequency is directly proportional to the current, that is, the oscillating frequency can be controlled by varying the current. The voltage-current converter produces this current for charging the capacitor C by converting the voltage signal (which is set by the dial and VCG) into a current signal. The polarity of the current is controlled by the flip-flop.

4.3 Start/Stop Operation

The start/stop control operation is done by controlling the constant current which flows into and out of the integrating capacitor. The circuit concept is shown in Figure 4-5.

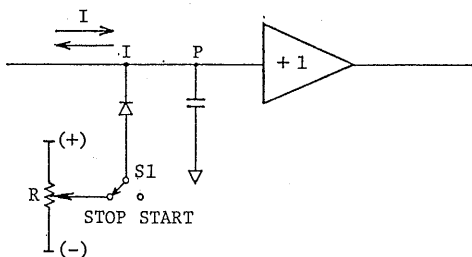

Figure 4-5

By means of switch $S1$ the potential of point P is fixed at the voltage divided by potentiometer R so that the oscillation stops at the level when the switch is closed and that it resumes at the same level when the switch is opened.

012230

4.4 DC Offset Operation

The DC offset operation is accomplished by adding a DC voltage to the AC signal at the output amplifier.

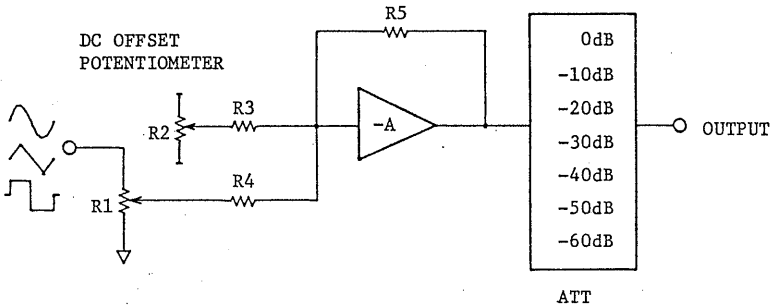

Figure 4-6

812237

5. APPLICATIONS

5.1 Application of VCG

5.1.1 V-F Converter

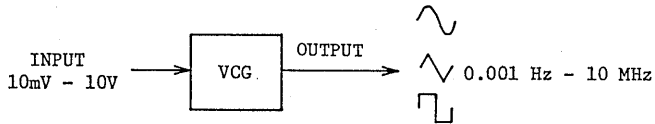

By setting the instrument in the VCG mode and applying an input voltage of 10 mV - 10 V, frequency can be varied by 1000 times within a single range.

5.1.2 Programmable Oscillator

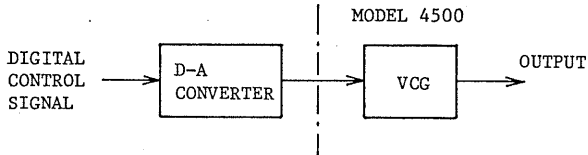

By connecting a D-A converter in the input circuit of the application of the above paragraph 5.1.1, the oscillating frequency is controllable with a digital level signal.

5.1.3 Swept Oscillation

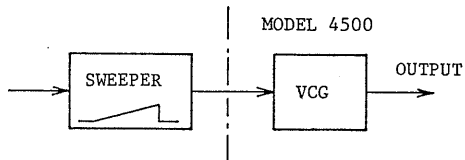

By applying to the VCG input terminal a sawtooth sweep signal which varies 10 mV - 10 V, the oscillating frequency can be swept to up to 1000 times in one range.

OUTPUT WAVEFORM



INPUT WAVEFORM

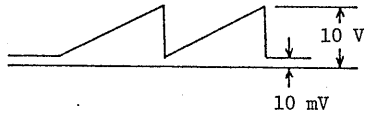

5.2 Use of DC Offset

When the DC offset feature is OFF, the output is referenced to the zero DC level. When an output in one polarity alone is required or when a DC component is required to be added to the AC signal, the DC offset feature is used. The DC offset range is ± 10 V with the attenuator set in the 0 dB state.

The DC offset knob should be adjusted taking into consideration the setting of the continuously variable AC output signal control knob, the maximum allowable voltage of the sum of DC component plus AC component is ± 10 V peak. If the voltage is higher than this, the signal is saturated.

5.3 Use as a Clock Generator

The instrument has an independent TTL output terminal. The output signal can be used as a clock signal for digital circuits.

617230